



HY2110

Datasheet

1-Cell Lithium-ion/Lithium Polymer
Battery Packs Protection ICs

Table of Contents

1. GENERAL DESCRIPTION	4
2. FEATURES	4
3. APPLICATIONS	4
4. BLOCK DIAGRAM	5
5. ORDERING INFORMATION	5
6. MODEL LIST	6
7. PIN CONFIGURATION AND PACKAGE MARKING INFORMATION	6
8. ABSOLUTE MAXIMUM RATINGS	7
9. ELECTRICAL CHARACTERISTICS	8
10. EXAMPLE OF BATTERY PROTECTION IC CONNECTION	9
11. DESCRIPTION OF OPERATION	10
11.1. Normal Status	10
11.2. Overcharge Status	10
11.3. Overdischarge Status	10
11.4. Charger Detection Status	11
11.5. Discharge Overcurrent Status (Discharge Overcurrent & Short Circuit)	11
11.6. Abnormal Charge Current Detection	12
11.7. 0V Battery Charging Function “Available”	12
11.8. 0V Battery Charging Function “Unavailable”	13
12. CHARACTERISTICS (TYPICAL DATA)	14
12.1. Overcharge Detection / Release Voltage, Overdischarge Detection / Release Voltage, Overcurrent Detection Voltage, and Delay Time	14
12.2. Current Consumption	15
13. PACKAGE INFORMATION	16
13.1. SOT-23-6(Type 1)	16
13.2. SOT-23-6(Type 2)	17
14. REVISION RECORD	18

Attention :

1. HYCON Technology Corp. reserves the right to change the content of this datasheet without further notice. For most up-to-date information, please constantly visit our website:
<http://www.hycontek.com> .
2. HYCON Technology Corp. is not responsible for problems caused by figures or application circuits narrated herein whose related industrial properties belong to third parties.
3. Specifications of any HYCON Technology Corp. products detailed or contained herein stipulate the performance, characteristics, and functions of the specified products in the independent state. We does not guarantee of the performance, characteristics, and functions of the specified products as placed in the customer's products or equipment. Constant and sufficient verification and evaluation is highly advised.
4. Please note the operating conditions of input voltage, output voltage and load current and ensure the IC internal power consumption does not exceed that of package tolerance. HYCON Technology Corp. assumes no responsibility for equipment failures that resulted from using products at values that exceed, even momentarily, rated values listed in products specifications of HYCON products specified herein.
5. Notwithstanding this product has built-in ESD protection circuit, please do not exert excessive static electricity to protection circuit.
6. Products specified or contained herein cannot be employed in applications which require extremely high levels of reliability, such as device or equipment affecting the human body, health/medical equipments, security systems, or any apparatus installed in aircrafts and other vehicles.
7. Despite the fact that HYCON Technology Corp. endeavors to enhance product quality as well as reliability in every possible way, failure or malfunction of semiconductor products may happen. Hence, users are strongly recommended to comply with safety design including redundancy and fire-precaution equipments to prevent any accidents and fires that may follow.
8. Use of the information described herein for other purposes and/or reproduction or copying without the permission of HYCON Technology Corp. is strictly prohibited.

1. General Description

The series of **HY2110** ICs is best created for single-cell lithium-ion/lithium polymer rechargeable battery protection and it also comprises high-accuracy voltage detectors and delay circuits.

These ICs are suitable for protecting single-cell rechargeable lithium-ion/lithium polymer battery packs against the problems of overcharge, overdischarge and overcurrent.

2. Features

The features of the whole series of HY2110 are as follows:

(1) High-accuracy voltage detection circuit

- Overcharge detection voltage: 4.250 to 4.350V, Accuracy: $\pm 50\text{mV}$
- Overcharge release voltage: 4.050 to 4.150V, Accuracy: $\pm 50\text{mV}$
- Overdischarge detection voltage: 2.30 to 2.90V, Accuracy: $\pm 100\text{mV}$
- Overdischarge release voltage: 2.90 to 3.00V, Accuracy: $\pm 100\text{mV}$
- Discharge overcurrent detection voltage: 150mV, Accuracy: $\pm 30\text{mV}$
- Short-circuiting detection voltage: 0.85V (fixed), Accuracy: $\pm 300\text{mV}$

(2) Delay times are generated by an internal circuit (external capacitors are unnecessary).

- Overcharge delay time: 100ms typ.
- Overdischarge delay time: 25ms typ.
- Discharge overcurrent delay time: 10ms typ.
- Short circuit delay time: 500 μs typ.

(3) Power-down function “Yes” / “No” are selectable (See Model List).

(4) Auto overdischarge recovery function “Yes” / “No” are selectable (See Model List).

(5) Low current consumption (Products with Power-down Function)

- Operation mode: 3.0 μA typ., 6.0 μA max. (VDD=3.9V)
- Ultra low power-down current: 0.1 μA max. (VDD=2.0V)

(6) High-withstanding-voltage device is used for charger connection pins

(CS pin and OC pin: Absolute maximum rating = 20 V)

(7) 0 V battery charge function “available” / “unavailable” are selectable (See Model List).

(8) Wide operating temperature range: -40°C to $+85^{\circ}\text{C}$

(9) Small package: SOT-23-6

(10) The HY2110 series are Halogen-free, green package

3. Applications

- 1-cell lithium-ion rechargeable battery packs
- 1-cell lithium polymer rechargeable battery packs

4. Block Diagram

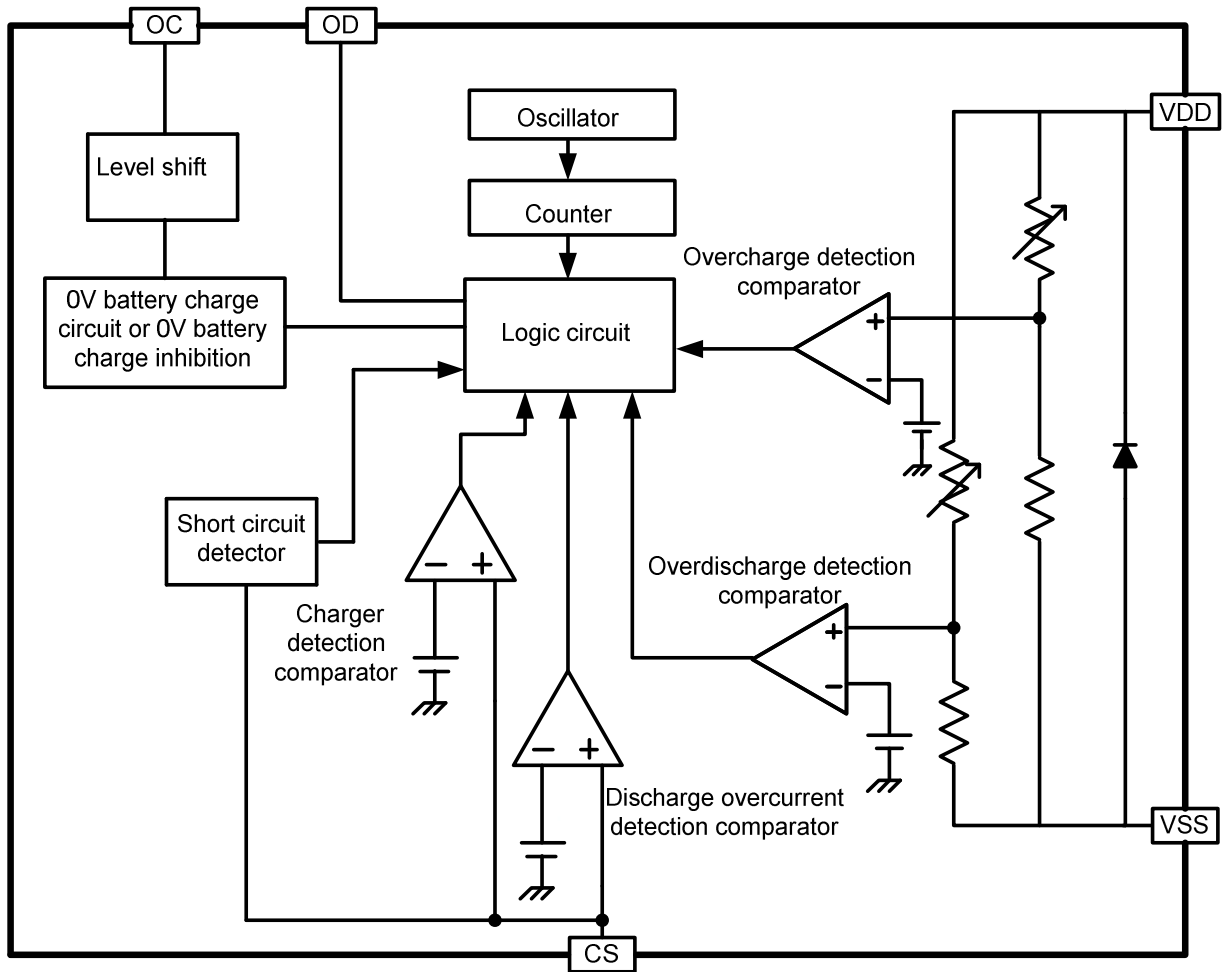

5. Ordering Information

- Product name define

HY2110-XX

Package name
B: SOT-23-6

Serial code
Sequentially set from A to Z

6. Model List

Model	Overcharge detection voltage	Overcharge release voltage	Overdischarge detection voltage	Overdischarge release voltage	Discharge overcurrent detection voltage	0V battery charge function	Other function
	V _{CU}	V _{CR}	V _{DL}	V _{DR}	V _{DIP}	V _{OCH}	-
HY2110-AB	4.30±0.05V	4.10±0.05V	2.4±0.1V	3.0±0.1V	150±30mV	available	Power-down function
HY2110-CB	4.28±0.05V	4.08±0.05V	2.4±0.1V	3.0±0.1V	150±30mV	available	Power-down function
HY2110-DB	4.28±0.05V	4.08±0.05V	2.4±0.1V	3.0±0.1V	150±30mV	available	Auto overdischarge recovery function

Remark: Please contact our sales office for the products with detection voltage value other than those specified above.

7. Pin Configuration and Package Marking Information

Pin No.	Symbol	Description
1	OD	MOSFET gate connection pin for discharge control
2	CS	Input pin for current sense, charger detect pin
3	OC	MOSFET gate connection pin for charge control
4	NC	No connection.
5	VDD	Power supply pin
6	VSS	Ground pin

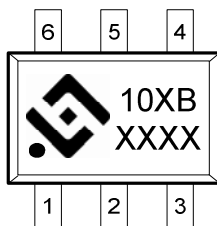

10 : Product Name
 XB : Serial code & Package name
 XXXX : Date code

8. Absolute Maximum Ratings

(VSS=0V, Ta=25°C unless otherwise specified)

Item	Symbol	Rating	Unit
Input voltage between VDD and VSS pin	V _{DD}	VSS-0.3 to VSS+10	V
OC output pin voltage	V _{OC}	VDD -20 to VDD +0.3	V
OD output pin voltage	V _{OD}	VSS-0.3 to VDD +0.3	V
CS input pin voltage	V _{CS}	VDD -20 to VDD +0.3	V
Operating Temperature Range	T _{OP}	-40 to +85	°C
Storage Temperature Range	T _{ST}	-40 to +125	°C
Power dissipation	P _D	250	mW

9. Electrical Characteristics

(VSS=0V, Ta=25°C unless otherwise specified)

Item	Symbol	Condition	Min.	Typ.	Max.	Unit
SUPPLY POWER RANGE						
Operating voltage between VDD pin and VSS pin	V _{DSOP1}	-	1.5	-	8	V
Operating voltage between VDD pin and CS pin	V _{DSOP2}	-	1.5	-	20	V
CURRENT CONSUMPTION (with Power-down Function)						
Supply Current	I _{DD}	VDD=3.9V	-	3.0	6.0	μA
Power-Down Current	I _{PD}	VDD=2.0V	-	-	0.1	μA
CURRENT CONSUMPTION (with Auto Overdischarge Recovery Function)						
Supply Current	I _{DD}	VDD=3.9V	-	3.0	6.0	μA
Overdischarge Current Consumption	I _{OD}	VDD=2.0V	-	2.0	3.0	μA
DETECTION VOLTAGE						
Overcharge Detection Voltage	V _{CU}	4.25V to 4.35V adjustable	V _{CU} -0.05	V _{CU}	V _{CU} +0.05	V
		4.25V to 4.35V adjustable -5°C to +55°C (Note)	V _{CU} -0.06	V _{CU}	V _{CU} +0.06	V
Overcharge Release Voltage	V _{CR}	4.05V to 4.15V adjustable	V _{CR} -0.05	V _{CR}	V _{CR} +0.05	V
Overdischarge Detection Voltage	V _{DL}	2.3V to 2.9V adjustable	V _{DL} -0.1	V _{DL}	V _{DL} +0.1	V
Overdischarge Release Voltage	V _{DR}	2.9V to 3.0V adjustable	V _{DR} -0.1	V _{DR}	V _{DR} +0.1	V
Discharge Overcurrent Detection Voltage	V _{DIP}	VDD=3.6V	V _{DIP} -30	V _{DIP}	V _{DIP} +30	mV
Short Circuit Detection Voltage	V _{SIP}	VDD=3.0V	0.55	0.85	1.15	V
Charger Detection Voltage	V _{CHA}		-	-0.3	-	V
DELAY TIME						
Overcharge Delay Time	T _{OC}	VDD=3.9V to 4.5V	50	100	150	ms
Overdischarge Delay Time	T _{OD}	VDD=3.6V to 2.0V	10	25	40	ms
Discharge Overcurrent Delay Time	T _{DIP}	VDD=3.6V	5	10	15	ms
Short Circuit Delay Time	T _{SIP}	VDD=3.0V	-	500	700	μs
CONTROL OUTPUT VOLTAGE(OD&OC)						
OD Pin Output "H" Voltage	V _{DH}		VDD-0.1	VDD-0.02	-	V
OD Pin Output "L" Voltage	V _{DL}		-	0.1	0.5	V
OC Pin Output "H" Voltage	V _{CH}		VDD-0.1	VDD-0.02	-	V
OC Pin Output "L" Voltage	V _{CL}		-	0.1	0.5	V
0V BATTERY CHARGE FUNCTION						
0V battery charge starting charger voltage	V _{0CH}	0V battery charging function "available"	1.2	-	-	V
0V battery charge inhibition charger voltage	V _{0IN}	0V battery charging function "unavailable"	-	-	0.5	V

NOTE: Since products are not screened at high and low temperature, the specification for this temperature range is guaranteed by design, not tested in production.

10. Example of Battery Protection IC Connection

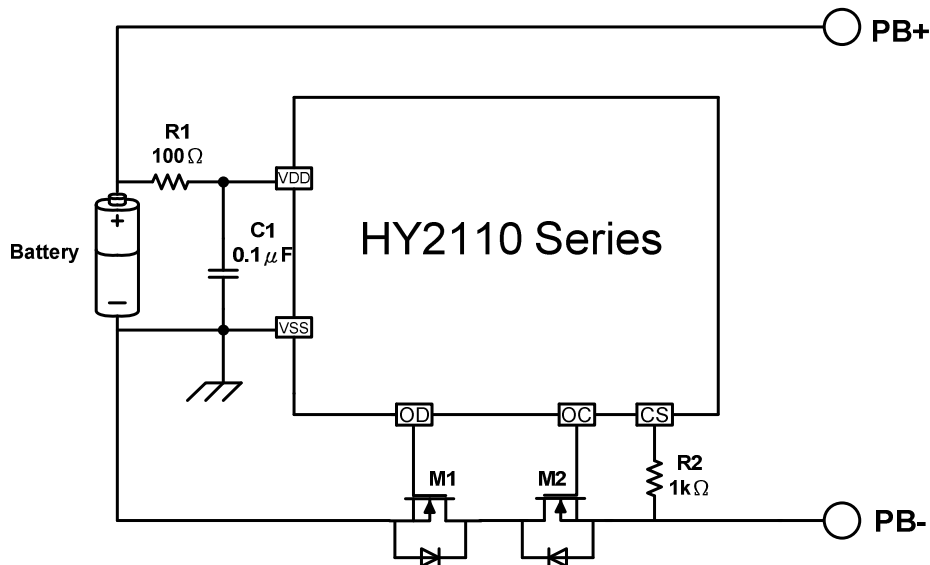

Symbol	Device Name	Purpose	Min.	Typ.	Max.	Remark
R1	Resistor	limit current, stabilize VDD and strengthen ESD protection	100Ω	100Ω	470Ω	*1
R2	Resistor	limit current	300Ω	1kΩ	2kΩ	*2
C1	Capacitor	stabilize VDD	0.01μF	0.1μF	1.0μF	*3
M1	N-MOSFET	Discharge control	-	-	-	*4
M2	N-MOSFET	Charge control	-	-	-	*5

- *1. R1 should be as small as possible to avoid lowering the overcharge detection accuracy due to current consumption. When a charger is connected in reversed, the current flows from the charger to the IC. At this time, if R1 is connected to high resistance, the voltage between VDD pin and VSS pin may exceed the absolute maximum rating.
- *2. If R2 has a resistance higher than 2kΩ, the charging current may not be cut when abnormal over-current appeared during charging. Please select as large a resistance as possible to prevent current when a charger is connected in reversed.
- *3. C1 will stabilize the supply voltage of VDD, the value of C1 should be equal to or more than 0.01μF.
- *4. If a FET with a threshold voltage equal to or higher than the overdischarge detection voltage is applied, discharging may be stopped before overdischarge is detected.
- *5. If the withstanding voltage between the gate and source is lower than the charger voltage, the FET may be destroyed.

Caution :

- (1)The above constants may be changed without notice , please download the most up-to-date datasheet on our website. <http://www.hycontek.com>
- (2)It is advised to perform thorough evaluation and test if peripheral devices need to be adjusted.

11. Description of Operation

11.1. Normal Status

This IC monitors the voltage of the battery connected between the VDD pin and VSS pin and the voltage difference between the CS pin and VSS pin to control charging and discharging.

When the battery voltage is in the range from overdischarge detection voltage (V_{DL}) to overcharge detection voltage (V_{CU}), and the CS pin voltage is in the range from the charger detection voltage (V_{CHA}) to discharge overcurrent detection voltage (V_{DIP}), the IC turns both the charging and discharging control MOSFET on. This condition is called the normal status. Under this condition, charging and discharging can both be carried out freely.

Caution: Discharging may not be enacted when the battery is first time connected. To regain normal status, CS and VSS pin must be shorted or the charger must be connected.

11.2. Overcharge Status

Under the normal status, as soon as the battery voltage becomes higher than the overcharge detection voltage (V_{CU}) during charging and the detection continues longer than the overcharge detection delay time (T_{OC}), the HY2110 series will turn the charging control MOSFET off (OC pin) to stop charging. This condition is called the overcharge status.

The overcharge status can be released by the following two cases:

- (1) The voltage of the battery cell is equal to or lower than the overcharge release voltage (V_{CR}) due to self-discharge.
- (2) When load is connected and the battery voltage falls below the overcharge protection voltage (V_{CU}).

11.3. Overdischarge Status

11.3.1. Products with Power-down Function

When the battery voltage falls below than the overdischarge detection voltage (V_{DL}) during discharging in the normal status and the detection continues longer than the overdischarge detection delay time (T_{OD}), the HY2110 series will turn the discharging control MOSFET off (OD pin) so as to stop discharging. This condition is called the overdischarge status.

When the MOSFET is off, CS pin voltage is pulled up by the resistor to VDD in the IC, at this time, the power consumption is reduced to the lowest. This condition is called the "SLEEP MODE".

The overdischarge status will be released by two cases:

- (1) When CS pin voltage is equal to or lower than the charger detection voltage (V_{CHA}) by charging and the VDD pin voltage is higher than overdischarge detection voltage (V_{DL}).
- (2) When CS pin voltage is equal to or higher than the charger detection voltage (V_{CHA}) by charging and the VDD pin voltage is higher than overdischarge release voltage (V_{DR}).

11.3.2. Products with Auto Overdischarge Recovery Function

When the battery voltage falls below than the overdischarge detection voltage (V_{DL}) during discharging in the normal status and the detection continues longer than the overdischarge detection delay time (T_{OD}), the HY2110 series will turn the discharging control MOSFET off (OD pin) so as to stop discharging. This condition is called the overdischarge status.

The overdischarge status will be released by three cases:

- (1) When CS pin voltage is equal to or lower than the charger detection voltage (V_{CHA}) by charging and the VDD pin voltage is higher than overdischarge detection voltage (V_{DL}).
- (2) When CS pin voltage is equal to or higher than the charger detection voltage (V_{CHA}) by charging and the VDD pin voltage is higher than overdischarge release voltage (V_{DR}).
- (3) Without connecting a charger, if the VDD pin voltage is higher than overdischarge release voltage (V_{DR}), the overdischarge status will be released, namely Auto Overdischarge Recovery Function .

11.4. Charger Detection Status

When the charger is connected to the overdischarge battery, if the voltage of CS pin is lower than charger detection voltage (V_{CHA}), based on the charger detection function, as long as the battery voltage is higher than overdischarge voltage (V_{DL}), the discharge status will be released and discharging control MOSFET (OD pin) will be turned on. This process is called the “charger detection status”.

Conversely, if CS pin’s voltage is not lower than charger detection voltage (V_{CHA}), the battery voltage has to reach the overdischarge release voltage (V_{DR}) to relieve the overdischarge status as usual.

11.5. Discharge Overcurrent Status (Discharge Overcurrent & Short Circuit)

Under normal condition, the HY2110 continuously monitors the discharge current by sensing the voltage of CS pin.

If the voltage of CS pin exceeds the overcurrent detection voltage (V_{DIP}) and the condition lasts beyond the overcurrent delay time (T_{DIP}), discharging will be suspended by turning off the discharge control MOSFET (OD pin). This condition is called the discharge overcurrent status.

If the voltage of CS pin exceeds the short circuit detection voltage (V_{SIP}) and the condition lasts beyond the short circuit delay time (T_{SIP}), discharging will be suspended by turning off the discharge control MOSFET (OD pin). This condition is called the short circuit status.

When the impedance between PB+ and PB- is larger than "automatic restoration impedance" and the voltage at the CS pin is lower than overcurrent detection voltage (V_{DIP}), the discharge overcurrent condition will be released.

11.6. Abnormal Charge Current Detection

Batteries under normal condition during the charging process, if the voltage of CS pin is lower than charger detection voltage (V_{CHA}), and this condition lasts for more than 12ms (typ.), the charging control MOSFET will be switched off (OC pin) to stop charging. This status is called "abnormal charge current detection".

After entering the status of abnormal charge current detection, one way to revert it to normal is to have the CS pin voltage higher than charger detection voltage (V_{CHA}).

Abnormal charge current detection voltage (V_{CHA}) for formularize:

$$\{I_{CHA} = |V_{CHA}| / R_{ON}\}. \quad R_{ON} \text{ is turn on resistance of MOSFET}$$

11.7. 0V Battery Charging Function "Available"

This function is used to recharge a connected battery which voltage is 0V due to self-discharge. When the 0V battery charge starting charger voltage (V_{0CH}) or a higher voltage is applied between PB+ and PB- pins by connecting a charger, the charging control MOSFET gate is fixed to the VDD pin voltage.

When the voltage between the gate and the source of the charging control MOSFET becomes equal to or higher than the turn on voltage due to the charger voltage, the charging control MOSFET is turned on to initiate charging. At this time, the discharging control MOSFET is off and the charging current flows through the internal parasitic diode in the discharging control MOSFET. When the battery voltage becomes equal to or higher than overdischarge voltage (V_{DL}), the HY2110 series will enter into the normal status.

Caution

- (1) Some battery providers do not recommend charging for a completely self-discharged battery. Please ask the battery provider to determine whether to enable or prohibit the 0V battery charging function.

- (2) The 0V battery charge function has higher priority than the charger current detection function. Consequently, a product in which use of the 0V battery charging function is enabled charges a battery forcibly and the charge overcurrent cannot be detected when the battery voltage is lower than overdischarge detection voltage (V_{DL}).

11.8. 0V Battery Charging Function “Unavailable”

When a battery which is internally short-circuited (0V battery) is connected, the unavailable 0V charging function will prohibit recharging. When the battery voltage equals to the 0V battery charge inhibition battery voltage (V_{0IN}) or lower, the charging control MOSFET gate is fixed to the PB- pin voltage to prohibit charging. When the battery voltage equals to the 0V battery charge inhibition battery voltage (V_{0IN}) or higher, charging can be implemented.

Caution

- (1) Some battery providers do not recommend charging for a completely self-discharged battery. Please ask the battery provider to determine whether to enable or prohibit the 0V battery charging function.

12. Characteristics (Typical Data)

12.1. Overcharge Detection / Release Voltage, Overdischarge Detection / Release Voltage, Overcurrent Detection Voltage, and Delay Time

(1) V_{CU} vs. T_a

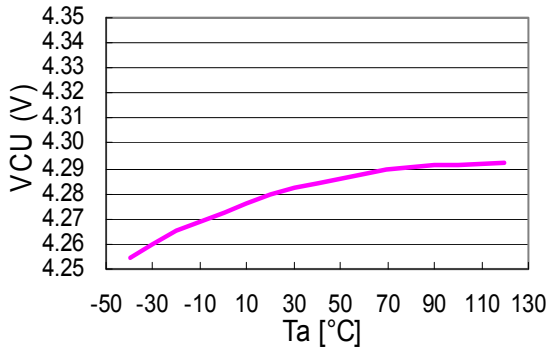

(2) V_{CR} vs. T_a

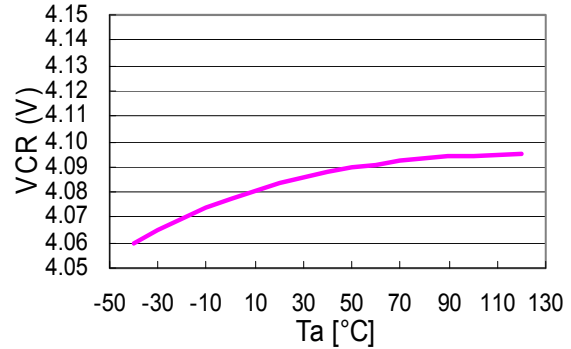

(3) V_{DL} vs. T_a

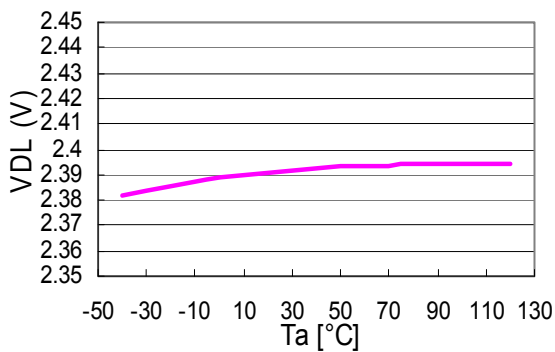

(4) V_{DR} vs. T_a

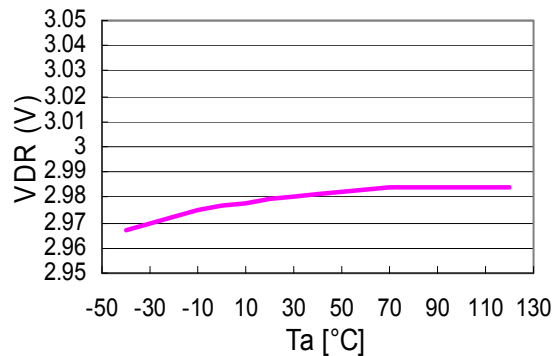

(5) T_{OC} vs. T_a

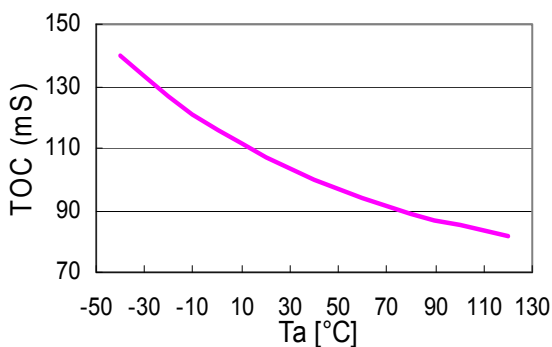

(6) T_{OD} vs. T_a

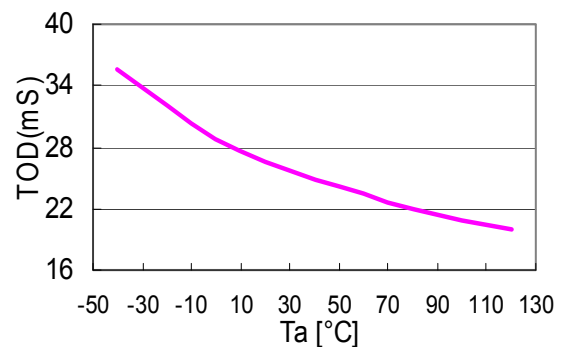

(7) V_{DIP} vs. T_a

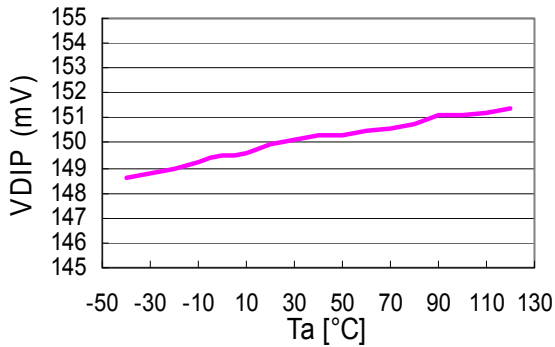

(8) T_{DIP} vs. T_a

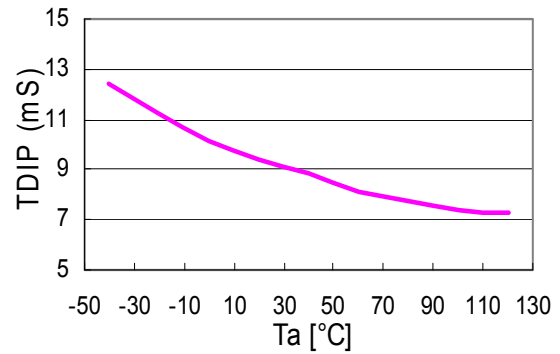

(9) V_{SIP} vs. T_a

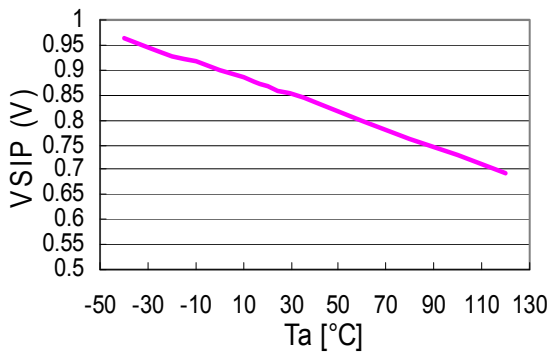

(10) T_{SIP} vs. T_a

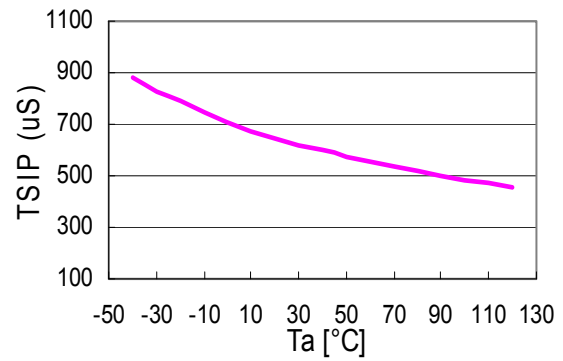

12.2. Current Consumption

(11) I_{DD} vs. T_a

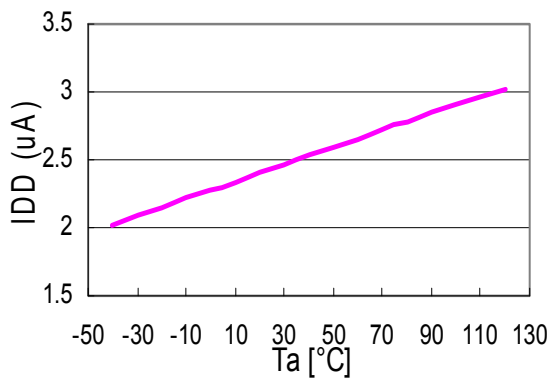

(12) I_{PD} vs. T_a

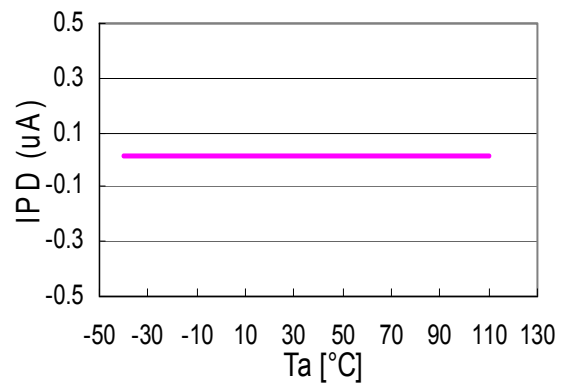

13. Package information

SOT-23-6 has two different size specifications.

13.1. SOT-23-6(Type 1)

NOTE: All dimensions are in millimeters.

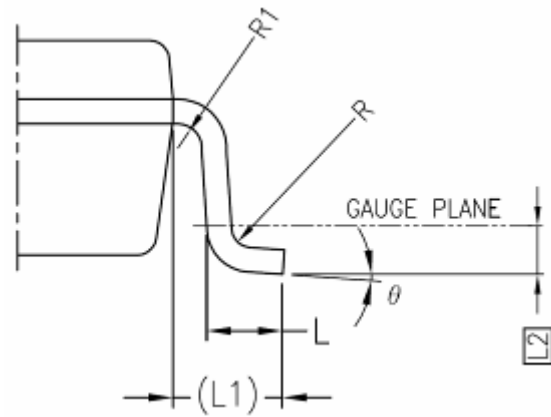
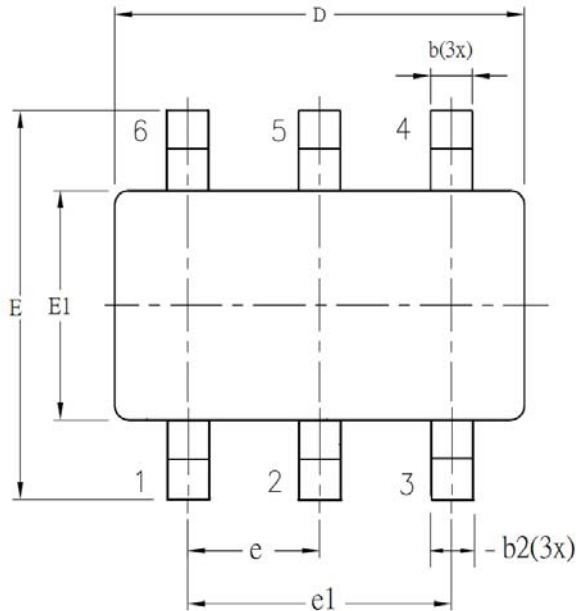

SYM BOL	ALL DIMENSIONS IN MILLIMETERS		
	MINIMUM	NOMINAL	MAXIMUM
A	-	1.30	1.40
A1	0	-	0.15
A2	0.90	1.20	1.30
b	0.30	-	0.50
b1	0.30	0.40	0.45
b2	0.30	0.40	0.50
c	0.08	-	0.22
c1	0.08	0.13	0.20
D	2.90 BSC		
E	2.80 BSC		
E1	1.60 BSC		
e	0.95 BSC		
e1	1.90 BSC		
L	0.30	0.45	0.60
L1	0.60 REF		
L2	0.25 BSC		
R	0.10	-	-
R1	0.10	-	0.25
θ	0°	4°	8°
$\theta 1$	5°	-	15°
$\theta 2$	5°	-	15°

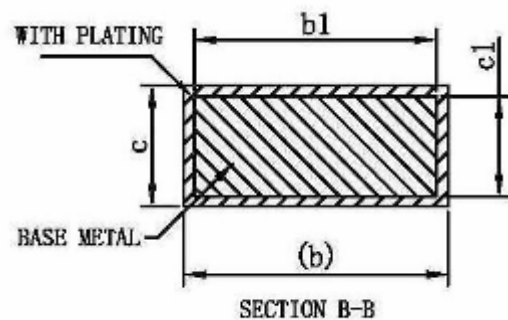
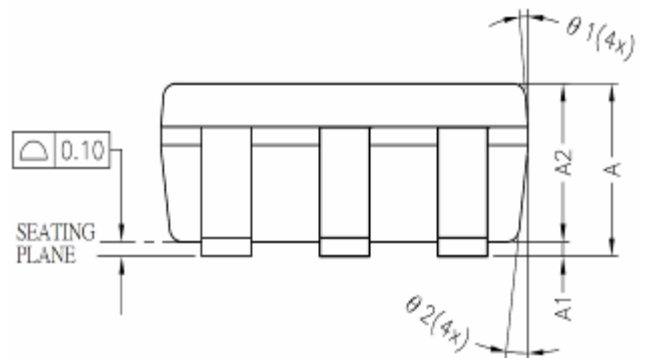

13.2. SOT-23-6(Type 2)

NOTE: All dimensions are in millimeters.

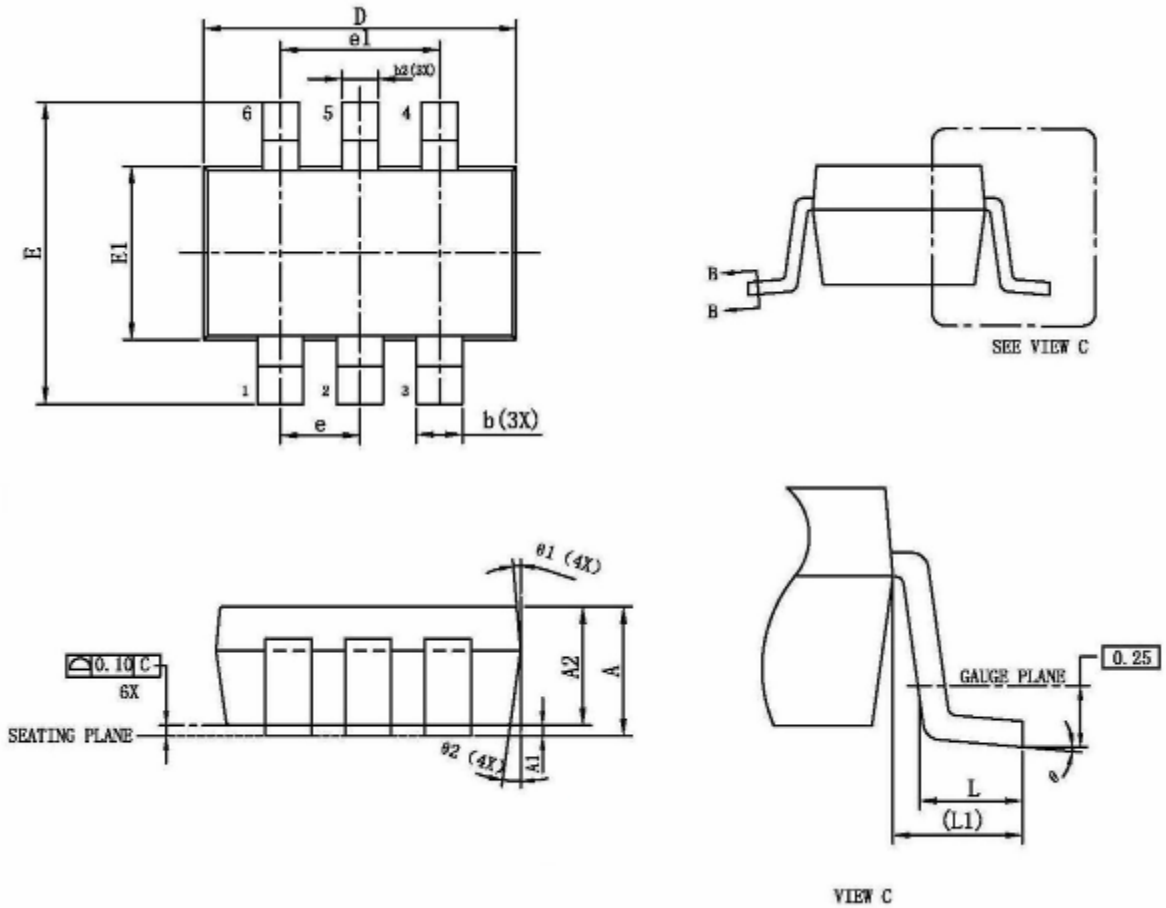

SYM BOL	ALL DIMENSIONS IN MILLIMETERS		
	MINIMUM	NOMINAL	MAXIMUM
A	-	1.30	1.40
A1	0.05	-	0.15
A2	0.90	1.20	1.30
b	0.40	-	0.55
b1	0.40	0.45	0.50
b2	0.25	-	0.40
c	0.08	-	0.20
c1	0.08	0.11	0.15
D	2.70	2.90	3.00
E	2.60	2.80	3.00
E1	1.50	1.60	1.70
e	0.95 BSC		
e1	1.90 BSC		
L	0.35	0.45	0.55
L1	0.60 REF		
θ	0°	5°	10°
θ1	3°	5°	7°
θ2	6°	8°	10°

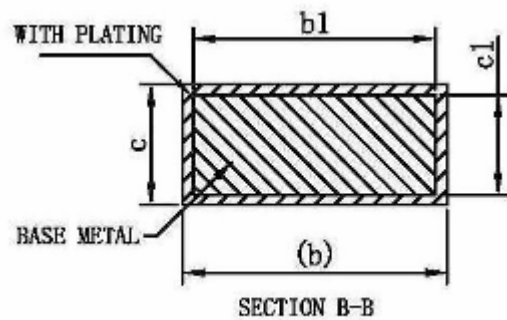

14. Revision record

Major differences are stated thereafter:

Version	Page	Revision Summary
V10	-	First Edition
V11	All	Add in new model no.:HY2110-CB
V12	All	Delete outdated model: HY2110-BB
	15	Revise package size
V13	All	Revised T_{SIP} parameter range of HY2110-AB
	All	Changed the 4th pin of HY2110-AB as NC
	15	Revise package size
V14	All	Add in new model no.:HY2110-DB
	16	Revise package size.
V15	6	Revise SOT-23-6 package marking rule.